

HUMP MAGNETS

APPLICATION:

Hump Magnets are designed to remove fine to large ferrous contaminants from gravity flow process systems. Hump Magnets provide uninterrupted protection to process equipment and ensure product purity. Puritan's Hump Magnets can be installed in applications involving moist, lumpy, granular or powder products.

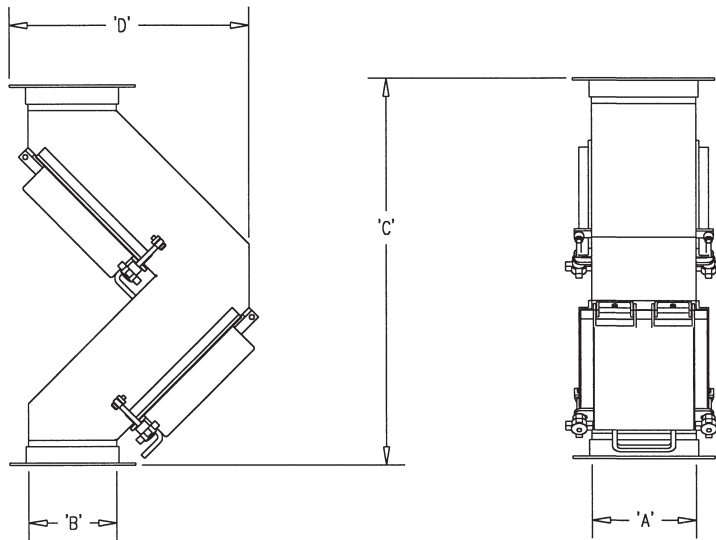
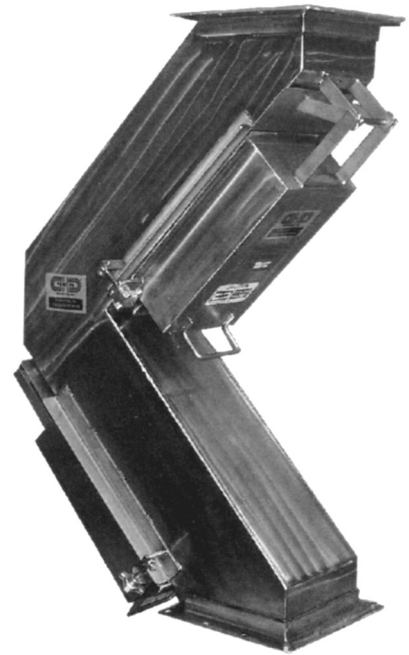

SPOUT ROUND OR SQUARE	MODEL		DIMENSION A		DIMENSION B		DIMENSION C		DIMENSION D		CAPACITY CU/FT HOUR	
	CERAMIC	RARE EARTH NEODYMIUM- IRON-BORON	inch/mm	inch/mm	inch/mm	inch/mm	inch/mm	inch/mm				
4.00	102	CHMD8TT	NHMD8TT	6.00	152	5.00	127	30.00	762	19.00	482	1,200
6.00	152	CHMD10TT	NHMD10TT	8.00	203	7.00	178	30.00	762	19.00	482	2,700
8.00	203	CHMD16TT	NHMD16TT	14.00	356	7.00	178	30.00	762	19.00	482	4,800
10.00	254	CHMD24TT	NHMD24TT	22.00	559	7.00	178	30.00	762	19.00	482	7,500
12.00	305	CHHD30TT	NHHD30TT	28.00	711	8.00	203	36.00	914	22.50	572	10,800
14.00	356	CHHD38TT	NHHD38TT	36.00	914	8.00	203	36.00	914	22.50	572	14,700
16.00	406	CHHD50TT	NHHD50TT	48.00	1,219	8.00	203	36.00	914	22.50	572	19,200
18.00	457	CHED51TT	NHED51TT	48.00	1,219	10.00	254	42.00	1,067	23.75	603	24,300
20.00	508	CHED63TT	NHED63TT	60.00	1,524	10.00	254	42.00	1,067	23.75	603	30,000

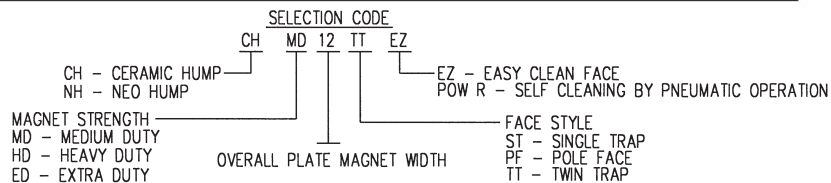

Note: Due to ongoing product development, certain specifications are subject to change without notice.

OPERATION:

As product enters the stainless steel housing it is directed to impact on the magnetic face of the first powerful Plate Magnet, where ferrous contaminants are tightly held to the Twin Trap face. Product continues to pass through the housing and then impacts on a second Plate Magnet where any ferrous contaminants not stopped by the first magnet are now caught. Each magnet covers the entire width of the housing with the flanged areas outside of the product flow area. This provides complete magnetic coverage across the housing with no gaps to allow ferrous contaminants to get through. Each magnet is hinged, latched, gasketed and includes a handle. Simply unlatch the magnet and it will pivot away from the housing allowing access to the captured ferrous contaminants.

CONSTRUCTION:

- 100% 304 stainless steel enclosed construction
- Highest available grades of magnet material with choices including Neodymium-Iron-Boron (rare earth), Samarium Cobalt (rare earth), Ceramic and Alnico
- Dual magnets for added protection
- Twin Trap face design for added protection
- Heavy duty stainless steel angle inlet and outlet flanges
- Heavy duty latches, hinges, and handle for easy access
- FDA approved white silicone sponge food grade gasket material

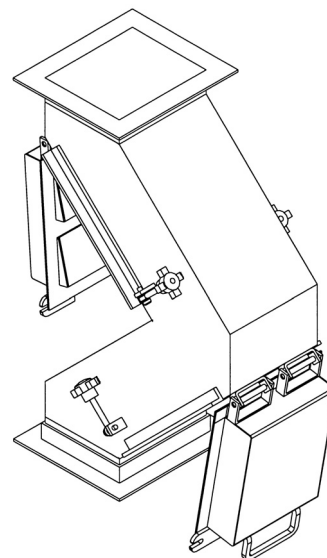

OPTIONS:

- 316L stainless steel and other alloy construction
- EZ CLEAN option with hinged stripper face to simplify cleaning
- POW-R CLEAN option to pneumatically operate hinged stripper face for automated self-cleaning
- Round inlet and outlet openings
- Sanitary construction
- Single Trap, Pole Face, or Suspended Face designs
- Various magnetic strengths to choose from

Maximum Energy Product
in Million Gauss-Oersted (MGO)

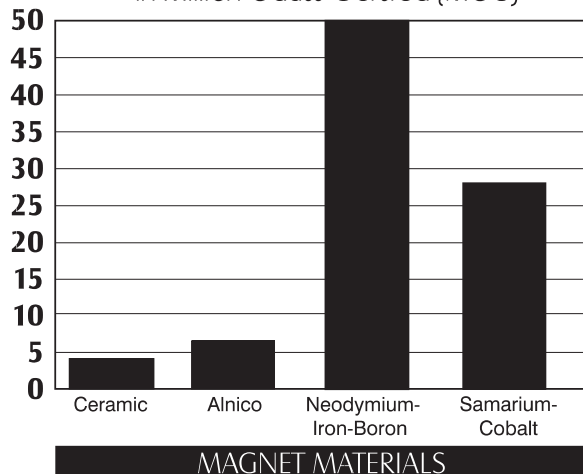

465 Glaspie Rd. Unit B • Oxford, MI 48371 • Tel: 248-628-3808 • Fax: 248-628-3844
www.puritanmagnetics.com • E-Mail: magnet@puritanmagnetics.com

For technical assistance or to order

1-800-787-3624

Solutions To Your Magnetic Needs

1-800-SUREMAG™

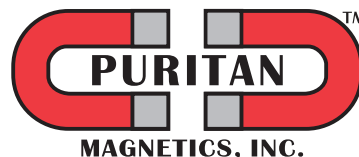
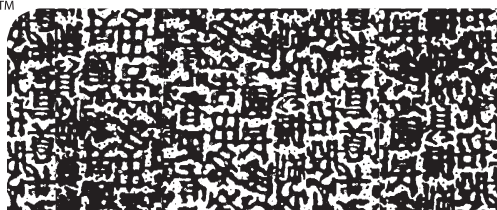

©1995 Puritan Magnetics, Inc.

Data sheet #2101 / Rev. 1/04